

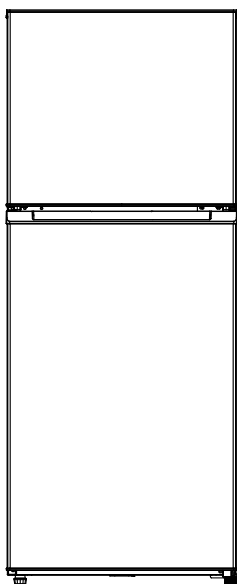

The Comfortable Choice

REFRIGERATOR / FREEZER

User Manual



Model:

TFF203WNTDM

TFF203SNTDM

IMPORTANT NOTE:

Thank you for selecting a TECO quality Refrigerator. Read this manual carefully before installing or operating your new unit. Make sure to save this manual for future reference.

The design and specifications are subject to change without prior notice for product improvement.





CONTENTS

Important Safety Instructions	1
Installation Instructions	4
Reversing the Door	5
Starting Instructions	7
Structure and Functions	8
Maintenance and Care of the Appliance	10
Troubleshooting	12
Repair, Service & Warranty	13
Specifications	14

Important Safety Instructions

- Thank you for purchasing our product and thank you for placing your confidence in us.
- Read this manual carefully before use. Follow instructions and keep the manual for future reference.
- Follow the operating instructions and safety notices in this manual.
- If any trouble arise, do not attempt to fix it yourself. Please contact TECO service on 1300 660 037 (8:30am - 4pm Mon~Fri AEST).
- This refrigerator is designed and approved for use with flammable R600a refrigerant.
- The appliance is specifically constructed for domestic use only. The appliance has not been designed or manufactured for professional use. TECO declines all responsibility for damage deriving from improper use of the appliance. The refrigerator has undergone the necessary tests on the tightness of the refrigeration circuit and complies with the safety regulations for electrical appliances.
- All images, illustrations and photos contained in this manual are for illustration purposes only and may differ from your appliance.

	This is a prohibition symbol. Any incomppliance with instructions marked with this symbol may result in damage to the product or endanger the personal safety of the user.
	This is a warning symbol. It is required to operate in strict observance of instructions marked with this symbol; or otherwise damage to the product or personal injury may be caused.
	This is a cautioning symbol. Instructions marked with this symbol require special caution. Insufficient caution may result in slight or moderate injury, or damage to the product.

- This appliance contains a small quantity of flammable, non-synthetic R600a refrigerant.
 - The room for installing the appliance must be at least 1m³ per 8g of refrigerant. The amount of refrigerant in the appliance can be found on the rating plate attached to the appliance.
 - If the refrigerant circuit should become damaged. Avoid open flames and sources of ignition. Disconnect the appliance from the mains power. Thoroughly ventilate the room in which the appliance is situated for several minutes.



Warning: risk of fire / flammable materials.

- The refrigerator is designed to operate on a single phase power supply within a voltage range of 220~240V/50Hz.
- The refrigeration system contains refrigerant. Do not allow any sharp objects to come in contact with the refrigerant system to avoid damage the refrigerant circuit.
- This product is for indoor use only.
- Do not place electrical items or cooking equipment nearby. Keep away from substances which could cause ignition and good ventilation shall be always maintained.
- Do not place objects on top of the appliance which are magnetic, heavy or filled with water.
- If the supply cord is damaged, it must be replaced by authorised TECO service personal, service agent or similarly qualified persons in order to avoid a hazard.
- Do not store flammable, explosive, volatile and highly corrosive materials in the refrigerator. Containers with flammable gases or liquids can leak at low temperature. There is a risk of explosion or fire.
- Do not splash water on the appliance. It may cause malfunction or electric shock.
- Always switch off and unplug appliance before cleaning.
- Keep ventilation openings, in the appliance enclosure or in the built-in structure, clear of obstruction.
- Do not use mechanical devices or other means to accelerate the defrosting process, other than those recommended by the manufacturer.
- Do not use electrical appliances inside the food storage compartments of the appliance.
- For appliances which use flammable insulation blowing gases, Please keep the products away from the fire or similar glowing substance.
- This appliance is intended to be used in household and similar applications such as:
 - staff kitchen areas in shops, offices and other working environments;
 - farm houses and by clients in hotels, motels and other residential type environments;
 - bed and breakfast type environments;
 - catering and similar non-retail applications.



- This appliance is not intended for use by persons (including children) with reduced physical, sensory or mental capabilities, or lack of experience and knowledge, unless they have been given supervision or instruction concerning use of the appliance by a person responsible for their safety.
- Young children should be supervised to ensure that they do not play with the appliance.
- Packing (e.g. wraps, polystyrene etc.) can be dangerous for children. There is a risk of suffocation. Keep packaging materials away from children.

- Contact your local authorities for correct method of disposal.
Dispose of all packaging in a responsible manner in accordance with local regulations.



Refrigerant and cyclopentane foaming material used for the refrigerator are flammable. Therefore, when the refrigerator is scrapped, it shall be kept away from any fire source and be recovered by a special recovering company with corresponding qualification other than be disposed by combustion, so as to prevent damage to the environment or any other harm.



When the refrigerator is scrapped, disassemble the doors, and remove gasket of door and shelves; put the doors and shelves in a proper place, so as to prevent trapping of any child.



Correct Disposal of this product :

This marking indicates that this product should not be disposed with other household wastes. To prevent possible harm to the environment or human health from uncontrolled waste disposal, recycle it responsibly to promote the sustainable reuse of material resources. To return your used device, please use the return and collection systems or contact the retailer where the product was purchased. They can take this product for environmental safe recycling.

Installation Instructions

- Before using the refrigerator for the first time, remove all of the packing materials, including the foam base and adhesive tape holding accessories in place; tear off the protective film on the doors and the refrigerator body.
- The refrigerator should be located in a well-ventilated indoor place; the ground shall be firm, flat surface that is strong enough to support the refrigerator when it is fully loaded.
- Choose a location that is not exposed to direct sunlight, high temperatures, heat sources such as a stove or radiator, or in a moist area. Do not choose a location where the temperature will go below 12°C as this could cause the refrigerator to not function properly.
- The top space of the refrigerator shall be greater than 30cm, and the refrigerator should be placed against a wall with a free distance more than 10cm to facilitate heat dissipation. This allows for proper air circulation. This appliance is intended to be free-standing and should not be built-in or placed in a recessed area.
- The refrigerator legs must be adjusted during installation in order to function properly. The leveling legs on the front corners can be adjusted by turning clockwise to raise the appliance, and counterclockwise to lower it. Be sure to have the appliance slope slightly backward to ensure that the door closes tightly.

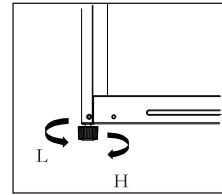
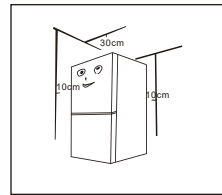

Adjusting procedures:

- a. Turn the feet clockwise to raise the refrigerator;
- b. Turn the feet counterclockwise to lower the refrigerator;
- c. Adjust the right and left feet based on the procedures above to a horizontal level.



Precautions before installation:

Before installation or adjusting of accessories, it shall be ensured that the refrigerator is disconnected from power. Precautions shall be taken to prevent fall of the handle from causing any personal injury.

Reversing the Door

- 1) Please power off this appliance before conduct this operation. Remove all food from door shelves.
- 2) Remove hole cap, the upper hinge cover, fitting screws of upper hinge, upper hinge and sleeve pipe, then uplift the freezer door until it is separated from cabinet completely.

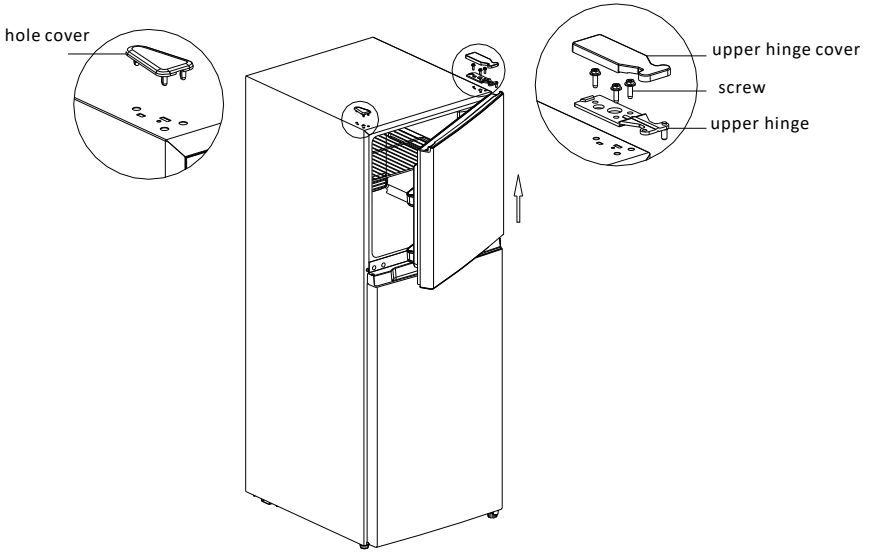

- 3) Unscrew the middle hinge screws, remove the middle hinge, and remove the two hole plug, a screw, a screw cap on the middle beam, then remove the refrigerator door.

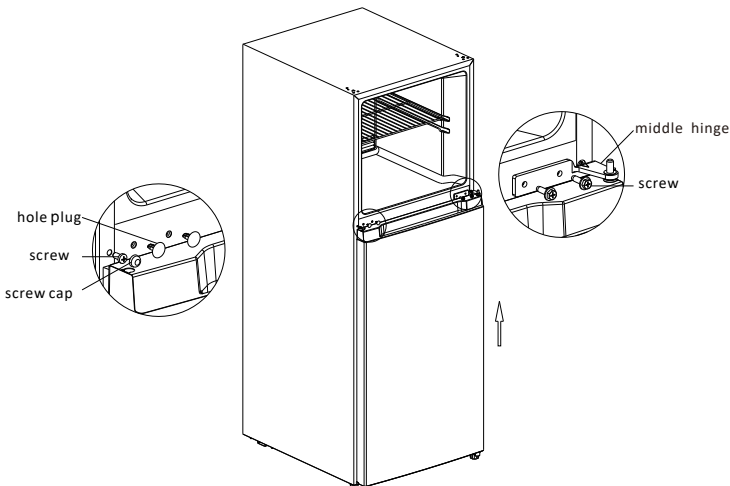

4) Remove the adjusting feet, lower hinge screw and lower hinge assembly, then install the lower hinge assembly on the other side of the box and install the adjusting feet on the side of the adjusting feet opening.

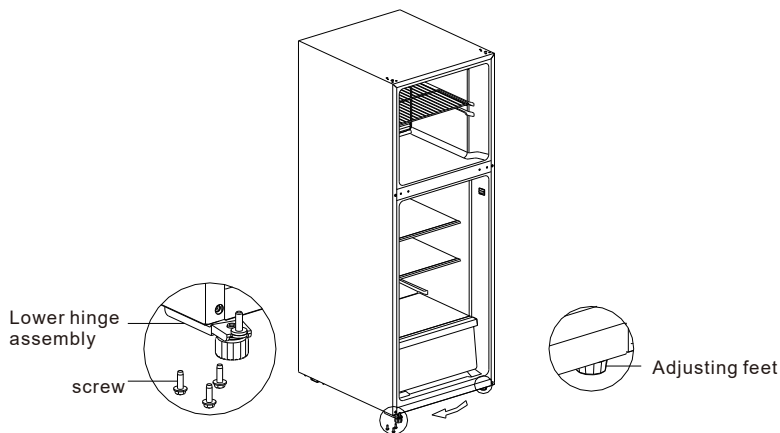

5) Dismantle the limit blocks and screws on the lower cover of both refrigerator door and freezer door, install them on the other side of both doors; then install the sleeve pipe on the upper cover of the refrigerator door on the other side.

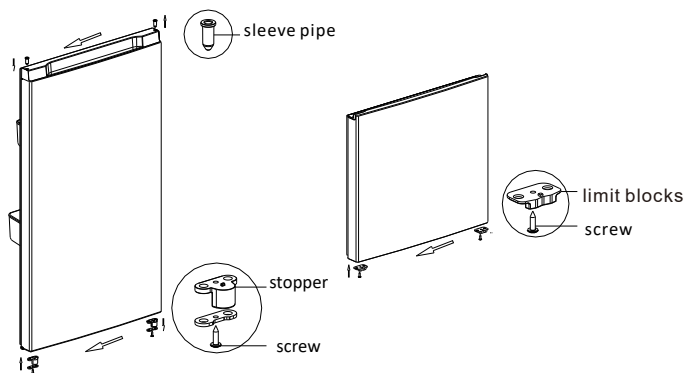

6) Install the refrigerator compartment door on the lower hinge and then install the middle hinge and hole caps.

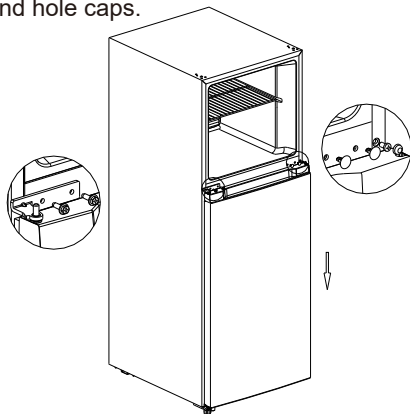

7) Install the freezer door on the middle hinge, and install the upper hinge, hinge cover and hole cover.

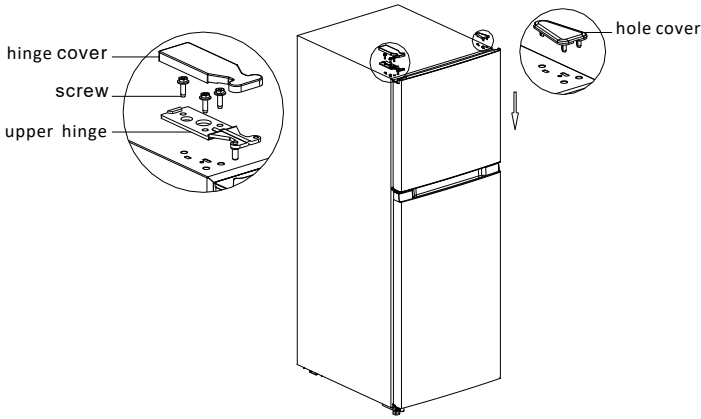

(The picture above is only for reference. The actual configuration will depend on the physical product or statement by the distributor).

Starting Instructions

- Before initial start, keep the refrigerator still for two hours before connecting it to power supply.
- Before putting any fresh or frozen foods, the refrigerator shall have run for 2-3 hours, or for above 4 hours in summer when the ambient temperature is high.
- Spare enough space for convenient opening of the doors and drawers or statement by the distributor.

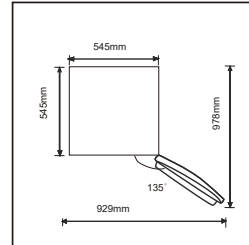

Energy saving tips

- The appliance should be located in the coolest area of the room, away from heat producing appliances or heating ducts, and out of the direct sunlight.
- Let hot foods cool to room temperature before placing in the appliance. Overloading the appliance forces the compressor to run longer. Foods that freeze too slowly may lose quality, or spoil.
- Be sure to wrap foods properly, and wipe containers dry before placing them in the appliance. This cuts down on frost build-up inside the appliance.
- Appliance storage bin should not be lined with aluminum foil, wax paper, or paper toweling. Liners interfere with cold air circulation, making the appliance less efficient.
- Organize and label food to reduce door openings and extended searches. Remove as many items as needed at one time, and close the door as soon as possible.

Structure and Functions

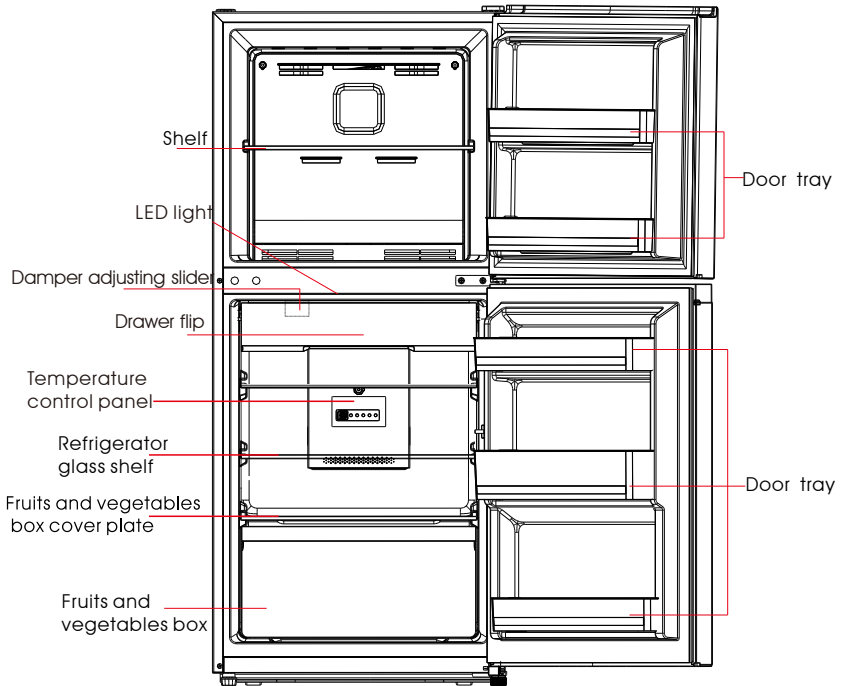

(The picture above is only for reference. The actual configuration will depend on the physical product or statement by the distributor)

Refrigerating chamber

- The Refrigerating Chamber is suitable for storage of a variety of fruits, vegetables, beverages and other food consumed in the short term.
- Cooking foods shall not be put in the refrigerating chamber until cooled to room temperature.
- Foods are recommended to be sealed up before putting into the refrigerator.
- The glass shelves can be adjusted up or down for a reasonable amount of storage space and easy use.

Freezing chamber

- The low temperature freezing chamber may keep food fresh for a longer period and it is mainly used to store frozen foods and making ice.
- The freezing chamber is suitable for storage of meat, fish and other foods not to be consumed in short term.
- Chunks of meat are preferably to be divided into small pieces for quick freezing and easy access. Please be noted food shall be consumed within the shelf time.

Functions

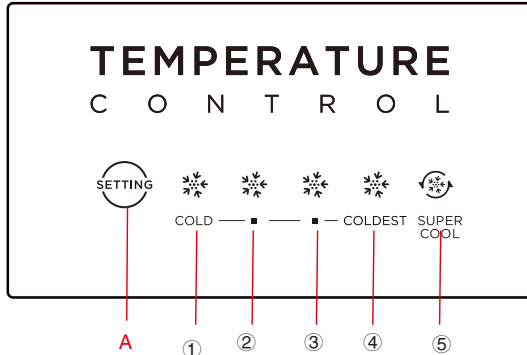

Notes:

(The picture above is only for reference. The actual configuration will depend on the physical product or statement by the distributor)

1)A: Setting button

2) LED Display

LED: ① gear(COLD)

LED: ② gear

LED: ③ gear (MID)

LED: ④ gear

LED: ⑤ gear (COLDER)

3) Display

When the refrigerator is power on, all the LED lights up for 3 seconds, the default temperature is MID (③ gear).

When there is a failure, the LED light shows the fault code, the LED light flashes as following table:

Error code	Error description
LED⑤,④flashing	Temperature sensor failure of refrigerating chamber
LED⑤,③ flashing	Defrost temperature sensor failure of freezing chamber
LED⑤,② flashing	The ambient temperature sensor failure

4) Gear setting

Every time you press setting button, the gear changes once, after selected the desired gear for 15s, the refrigerator will run according to the setting value.



5) Memory Function

The refrigerator can keep the memory of the setting during a power outage.

6) Damper adjusting slider

The initial position of the damper adjusting slider is on the far right side.

For better user experience, it is recommended to push the slider to right position, and select the setting to MID position. If it is not cool enough inside the refrigerator compartment, please check whether the slider is in left position, adjust the slider to the right side.

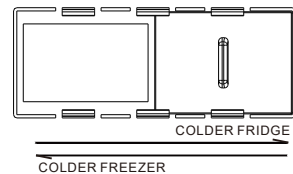

Maintenance and Care of the Appliance

- Dusts behind the refrigerator and on the ground shall be timely cleaned to improve the cooling effect and energy saving.
- Check the door gasket regularly to make sure there are no debris. Clean the door gasket with a soft cloth dampened with soapy water or diluted detergent.
- The interior of the refrigerator should be cleaned regularly to avoid odor. Please turn off the power before cleaning interior, remove all foods, drinks ,shelves, drawers, etc.
- Use a soft cloth or sponge to clean the inside of the refrigerator, with two tablespoons of baking soda and a quart of warm water. Then rinse with water and wipe clean. After cleaning, open the door and let it dry naturally before turning on the power.
- For areas that are difficult to clean in the refrigerator (such as narrow sandwiches, gaps or corners), it is recommended to wipe them regularly with a soft rag, soft brush, etc. and when necessary, combined with some auxiliary tools (such as thin sticks) to ensure no contaminants or bacterial accumulation in these areas.
- Do not use soap, detergent, scrub powder, spray cleaner, etc., as these may cause odors in the interior of the refrigerator or contaminated food.
- Clean the bottle frame, shelves and drawers with a soft cloth dampened with soapy water or diluted detergent. Dry with a soft cloth or dry naturally.
- Wipe the outer surface of the refrigerator with a soft cloth dampened with soapy water, detergent, etc., and then wipe dry.
- Do not use hard brushes, clean steel balls, wire brushes, abrasives (such as toothpastes), organic solvents (such as alcohol, acetone, banana oil, etc.), boiling water, acid or alkaline items, which may damage the fridge surface and interior. Boiling water and organic solvents such as benzene may deform or damage plastic parts.
- Do not rinse directly with water or other liquids during cleaning to avoid short circuits or affect electrical insulation after immersion.



Please unplug the refrigerator for defrost and cleaning.

Cleaning the glass shelf

- Lift up the front of glass shelf, and then pull out;
- Remove the glass shelf and clean as needed;
- The reverse operation is for installation of glass shelf.

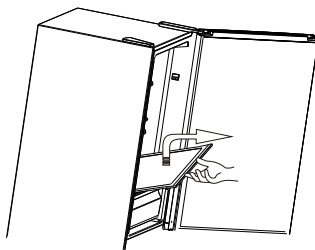

Defrosting

- The refrigerator is made based on the air-cooling principle and thus has an automatic defrosting function. Frost formed due to change of season or temperature may also be manually removed by disconnection of the appliance from the power supply or by wiping with a dry towel.

Out of operation

- Power outage: In case of a power outage, even if it is in summer, foods inside the appliance can be kept for several hours; during the power outage, the times of door opening shall be reduced, and no more fresh food shall be put into the appliance.
- Long-time non-use: The appliance shall be unplugged and then cleaned; then the doors are left open to prevent odor.
- Moving: Before the refrigerator is moved, take all objects inside out, fix the glass partitions, vegetable holder, freezing chamber drawers and etc. with tape, and tighten the leveling feet; close the doors and fix them with tape. During moving, the appliance shall not be laid upside down or horizontally, or be vibrated; the inclination during movement shall be no more than 45°.



The appliance shall run continuously once it is started. Generally, the operation of the appliance shall not be interrupted; otherwise the service life may be impaired.

Troubleshooting

Failed operation	<p>Check whether the appliance is connected to power or whether the plug is in well contact .</p> <p>Check whether the voltage is too low.</p> <p>Check whether there is a power failure or partial circuits have tripped.</p>
Odor	<p>Odorous foods shall be tightly wrapped.</p> <p>Check whether there is any rotten food.</p> <p>Clean the inside of the refrigerator.</p>
Long-time operation of the compressor	<p>Long operation of the refrigerator is normal in summer when the ambient temperature is high.</p> <p>It is not recommended having too much food in the appliance at the same time.</p> <p>Food shall get cool before being put into the appliance.</p> <p>The doors are opened too frequently.</p>
Light fails to get lit	<p>Check whether the refrigerator is connected to power supply and whether the illuminating light is damaged. (Any replacement of the LED lamps shall be made by the authorised agent or similar qualified personal).</p>
Doors cannot be properly closed	<p>The door is stuck by food packages.</p> <p>The refrigerator is tilted.</p>
Loud noise	<p>Check whether the floor is level and whether the refrigerator is placed stably.</p> <p>Check whether accessories are placed at proper locations.</p>
Door seal fails to be tight	<p>Remove foreign matters on the door seal.</p> <p>Heat the door seal and then cool it for restoration (or blow it with an electrical drier or use a hot towel for heating).</p>
Water pan overflows	<p>There is too much food in the chamber or food stored contains too much water,resulting in heavy defrosting.</p> <p>The doors are not closed properly, resulting in frosting due to entry of air and increased water due to defrosting.</p>
Hot housing	<p>Heat dissipation of the built-in condenser via the housing, which is normal.</p> <p>When housing becomes hot due to high ambient temperature and storage of too much food,it is recommended to provide sound ventilation to facilitate heat dissipation.</p>
Surface condensation	<p>Condensation on the exterior surface and door seals of the refrigerator is normal when the ambient humidity is too high. Just wipe the condensate with a clean towel.</p>
Abnormal noise	<p>Buzz: The compressor may produce buzzes during operation, and the buzzes are loud particularly upon start or stop. This is normal.</p> <p>Creak: Refrigerant flowing inside of the appliance may produce creak, which is normal.</p>

Repairs, Service & Warranty

It is hazardous for anyone installing, removing, altering, repairing, servicing, testing or certifying the gas system of a gas device (i.e. charging, discharging or breaking into the refrigeration system that uses hydrocarbon refrigerants).

Only an Authorised Service Person can carry out servicing or repairs to this appliance. In Queensland the authorised person must hold a Gas Work Authorisation for hydrocarbon refrigerants, before carrying out servicing or repairs which involve the removal of covers.

IF SERVICE IS REQUIRED

If you have a problem, and the problem persists after you have made the checks mentioned in this manual, contact:
TECO Australia's Service on 1300 660 037 (8:30am - 4pm Mon~Fri AEST).

For warranty details please visit

www.teco.com.au

Service Email : had.service@teco.com.au

Spare Parts : had.parts@teco.com.au

Specifications

Model Number		TFF203WNTDM TFF203SNTDM
Group		5T
Total Storage Volume (L)		203
Volume (L)	Refrigerator	143
	Freezer	60
Voltage (V)		220 - 240
Frequency (Hz)		50
Rated Current (A)		1.2
Rated Defrost Power (W)		170
Refrigerant		R600a/35g
Climate class		T
Electric shock protection type		I
Net Weight (kg)		43
Dimension (mm)	Width	545
	Depth	610
	Height	1375

E&OE

NOTE: This product is subject to continuous improvement, specifications are subject to change without prior notice. This product was tested in accordance with Electrical safety of electrical appliances AS/NZS 60335, Energy consumption and performance AS/NZS 4474.1 and Energy labeling and minimum energy performance AS/NZS 4474.2.

Did you know?

TECO Australia's product range also includes:

- ◆ Top Load Clothes Washers
- ◆ Front Load Clothes Washers
- ◆ Auto Sensing Vented Clothes Dryers
- ◆ Heat Pump Clothes Dryer
- ◆ Refrigerators
- ◆ Chest and Vertical Freezers
- ◆ Bar Fridges
- ◆ Televisions
- ◆ Air Curtains
- ◆ Air Conditioners

Visit **www.teco.com.au** for our full range.



WARRANTY INFORMATION

Teco's warranty information for the product purchased is available at www.teco.com.au.

A copy of the warranty may also be obtained by contacting Teco's Warranty and Service Department on 1300 660 037 during business hours (Mon - Fri 8.30am - 4pm AEST).

To arrange for servicing of a Teco product, please contact our Warranty and Service Department on 1300 660 037 during business hours (Mon - Fri 8.30am - 4pm AEST).

To assist in processing any warranty claim that you may have Teco recommends that you:

1. Complete the following information in relation to your purchase:

Name of retailer: _____

Name of owner: _____

Date of purchase: _____

Model No. : _____

Serial No. : _____

MFG code: _____

2. Retain proof of your purchase for any warranty claim. Ideally this proof of purchase will be the tax invoice issued for your purchase.
3. Complete the following information in relation to the person that installed your Teco appliance (if applicable):

Installer's name: _____

Telephone No.: _____

Licence No. _____